



TOWN OF JACKSON COUNCIL WORKSHOP AGENDA DOCUMENTATION

PREPARATION DATE: July 15, 2014
MEETING DATE: July 8, 2014

SUBMITTING DEPARTMENT: Fair Board/Parks and Recreation
DEPARTMENT DIRECTOR: Steve Ashworth
PRESENTER: Steve Harrington, Tracy Ross, & Steve Ashworth

SUBJECT: Teton County/Town of Jackson Fairgrounds Development Plans for 2010 SPET

STATEMENT/PURPOSE

The purpose of the agenda item is to provide the Teton County Fair Board and staff an opportunity to present plans for review and comment of proposed 2010 SPET expenditures. Upon review of the council, staff will prepare final documents for submission to the town planning and building department.

BACKGROUND/ALTERNATIVES

In 2010, voters approved a SPET ballot question authorizing the repair, renovation and addition of improvements on the Teton County Fairgrounds. The projects identified included: roof covers over the south bleachers; energy upgrades to the lighting system; replacement of the restroom; replacement of the crow's nest and ticket booth; renovation of the arena to include fencing, chutes, runs, etc.; and installation of drainage system.

Staff and the Fair Board have completed the first two components of the project, and as the funds have become available are now ready to tackle the remaining. Jorgensen Engineering and CTA Architects have been retained to design the improvements, and Parks and Recreation Staff will oversee execution of bidding and construction with consultation and assistance from the consultant team.

Staff is presenting drawings for this phase of development. The project highlights are as follows:

1. **Arena Renovation-** The proposed plan replaces perimeter arena stock fencing, relocates the bucking chutes, and re-arranges the location of bleachers. The primary justification for the re-arrangement of uses is to provide increased safety and a higher quality of spectator experience. The new design completely separates guests from participants and animals. Additionally, the design creates better site lines, and easier access to concessions and restrooms.
2. **Restroom-** The restroom design relocates the restroom south of its existing location. This will allow the restroom to be utilized within the secured ticketed area, as well as from the outside non ticketed area. The restroom will provide more adequate capacity for events, and will also include a second concession facility.
3. **Crow's Nest and Ticket Booth-** The crow's nest will be relocated to the west end of the arena, allowing for safer participant experience, as well as increase spectator value. The crow's nest will also incorporate the necessary space and accommodation for a variety of different events, and most importantly replace the failing existing structure. The ticket booth will be installed on the southeast corner of the arena, and will provide the adequate space and configuration for event ticket sales. All building, including the restroom, will be of a western heritage character, utilizing weathered barn wood siding and rusted corrugated metal roofing.
4. **Drainage-** The consultant team has been working with the Town Engineer to most effectively manage on site storm water. The areas of greatest concern are the northeast corner of the Heritage arena moving east around the back of the arena to the eastern access point to Snow King Ave. The proposed plan is to install a series of drainage inlets to capture the runoff, and then connect the storm water discharge underground to the existing

TOJ storm water system. This system shall be designed and sized to accommodate future growth and development opportunities on the site.

5. Snow King Ave. Perimeter Fencing- The board and staff are working to enhance the street presence of the fairgrounds, and the most significant element of this is the replacement of the existing chain link fencing. The proposal is to install a more decorative 6' high black iron fence in approximately the same location of the existing.

ATTACHMENTS

Arena Site Plan
Restroom Plan and Elevations
Crow's Nest and Ticket Booth Plan and Elevations

FISCAL IMPACT

All improvements shall be funded utilizing the 2010 SPET funding, FY15 Teton County Fairgrounds Approved Capital Budget, and Teton County Fairgrounds Reserve Fund if necessary.

RECOMMENDATION/MOTION

Staff recommends that council approve the proposed development plan as presented by the Fair Board, and authorize them to proceed to building permit application process.

“Move to approve site and architectural development plans for the Teton County/Town of Jackson Fairgrounds as presented by staff, and authorize staff to proceed with applicable building and planning permit submissions, and consequent construction development.”

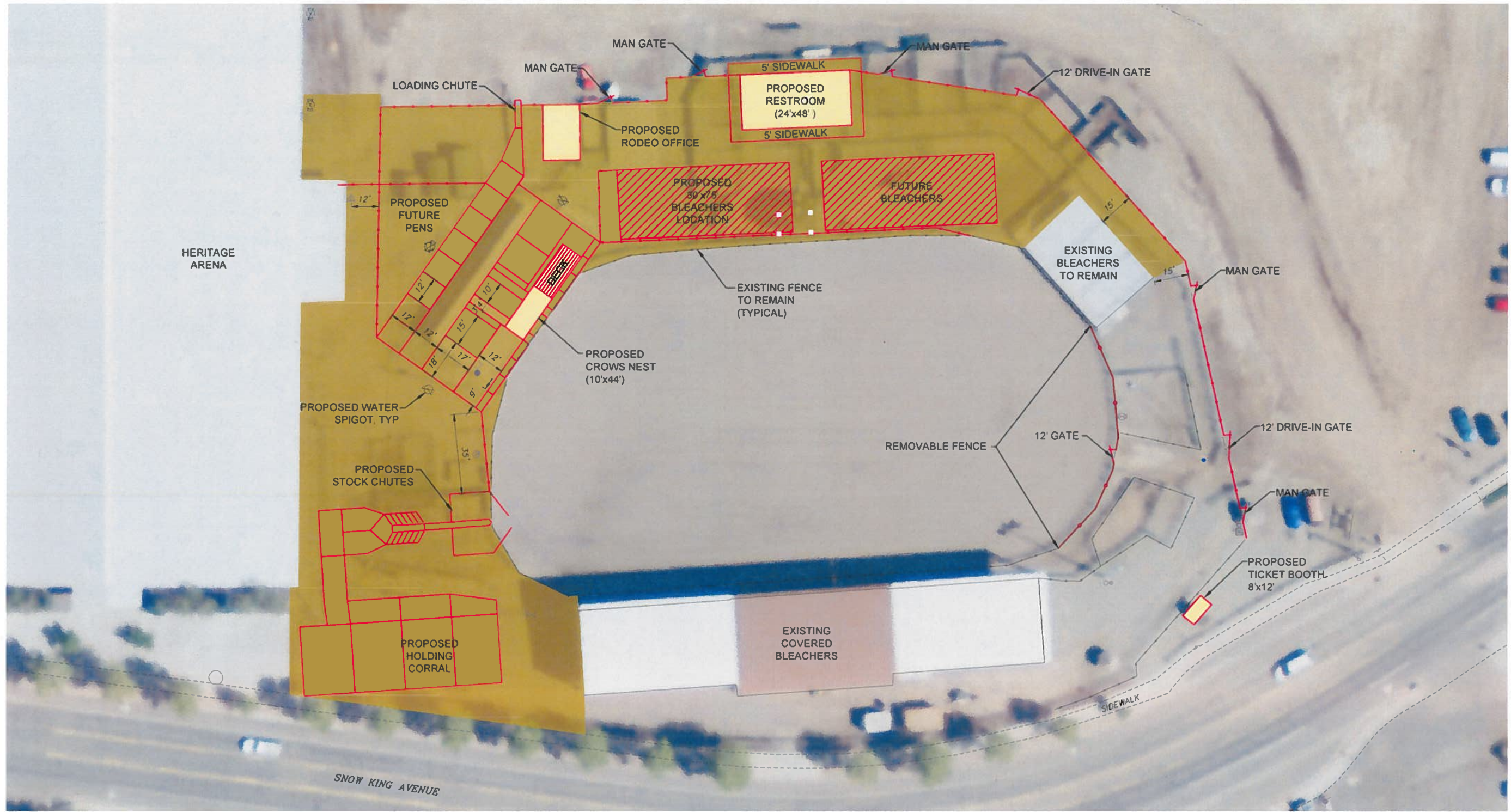

- = LEGEND =**
- sanitary sewer manhole
 - gasline marker
 - water spigot
 - hose bb
 - communication pedestal
 - bollard
 - light pole
 - flag pole
 - sign, single post / double post
 - lease boundary, approximate
 - existing fence, various types TO REMAIN
 - existing fence, various types TO BE REMOVED
 - proposed fence, various types
 - proposed bucking chutes, stock chutes and holding corrals as indicated

= NOTES =

Topographic survey was conducted in October, November, and December 2013 and prepared under the direction of Darryl W. Johnson, Wyoming PE & LS 9351. Survey does not include an engineering review.

Locations of utilities depicted hereon are limited to structures visible above ground surface; underground location must be verified prior to any construction activity. At time of survey, property was snow-covered which may affect accuracy of collected data.

Easements or encumbrances may exist on the subject property. A thorough search of public records was not conducted.

Building setbacks are not depicted. Confirm allowed location of any proposed improvements with applicable government agencies.

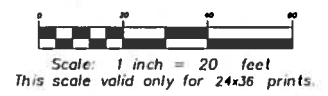

- PRELIMINARY -
 SUBJECT TO CORRECTION
 AND APPROVAL

**ILLUSTRATIVE MAP
 SHOWING
 RODEO ARENA
 POTENTIAL CHANGES**
 Located In
 Section 33
 T.41N., R.116W., 6th P.M.
 Teton County, Wyoming

H:\2013\11065\101 - SPT - 24\locat\1065 01.dwg R10 Rodeo Site.dwg

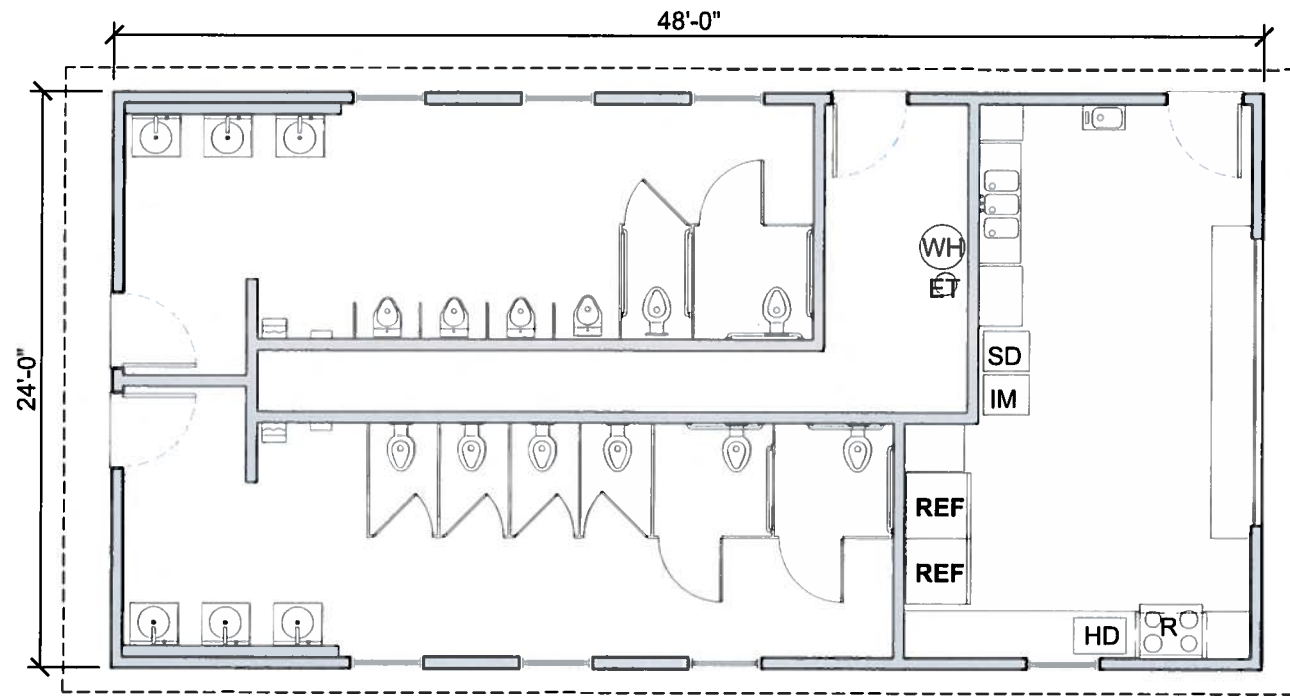
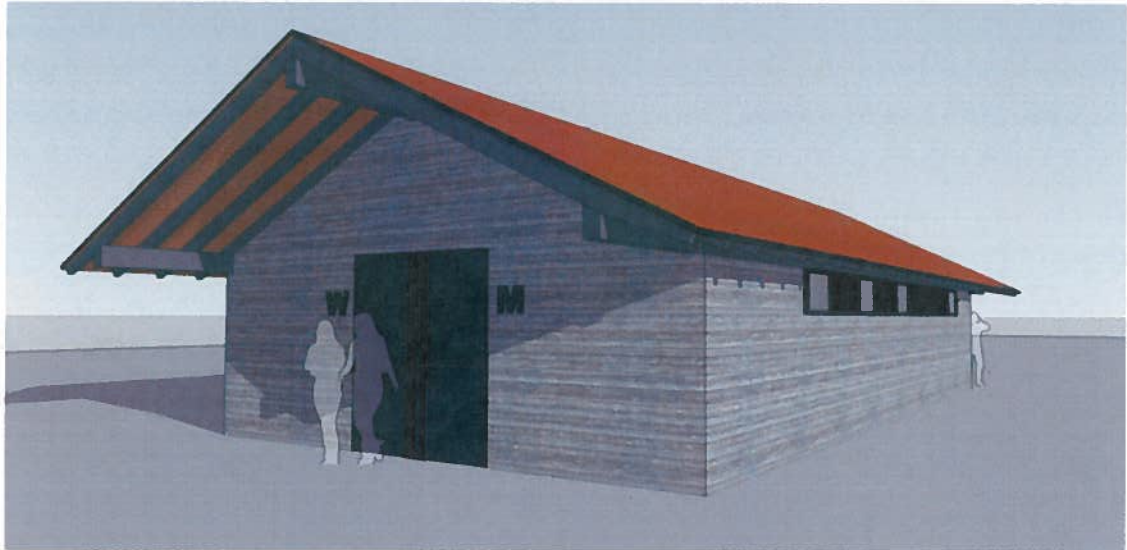
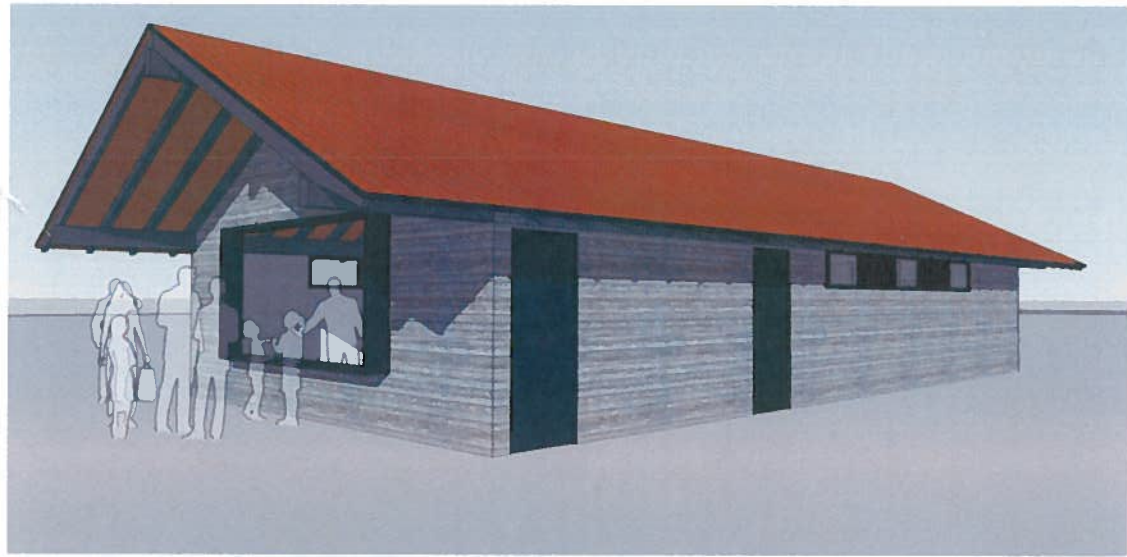

1
SD1

**Concessions & Restrooms
Floor Plan**

1/8"=1'-0"

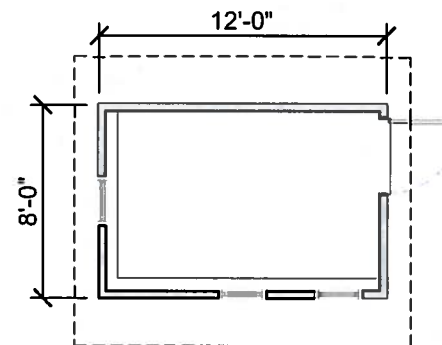

2
SD1

Ticket Booth

1/8"=1'-0"

NOT FOR CONSTRUCTION - PRELIMINARY DESIGN

TETON COUNTY FAIR GROUNDS

CONCESSIONS RESTROOMS & TICKETS

JACKSON WY

CTA
JACKSON, WY
(307)733-9955
Fax (307)733-9954

TAG #	REVISION	DATE
1	SD1	6/25/14
DRAWN BY	REF SHEET #	
AJ		
CHECKED BY	SHEET#	
BH		
CTA #	JACFAIR2	
		1

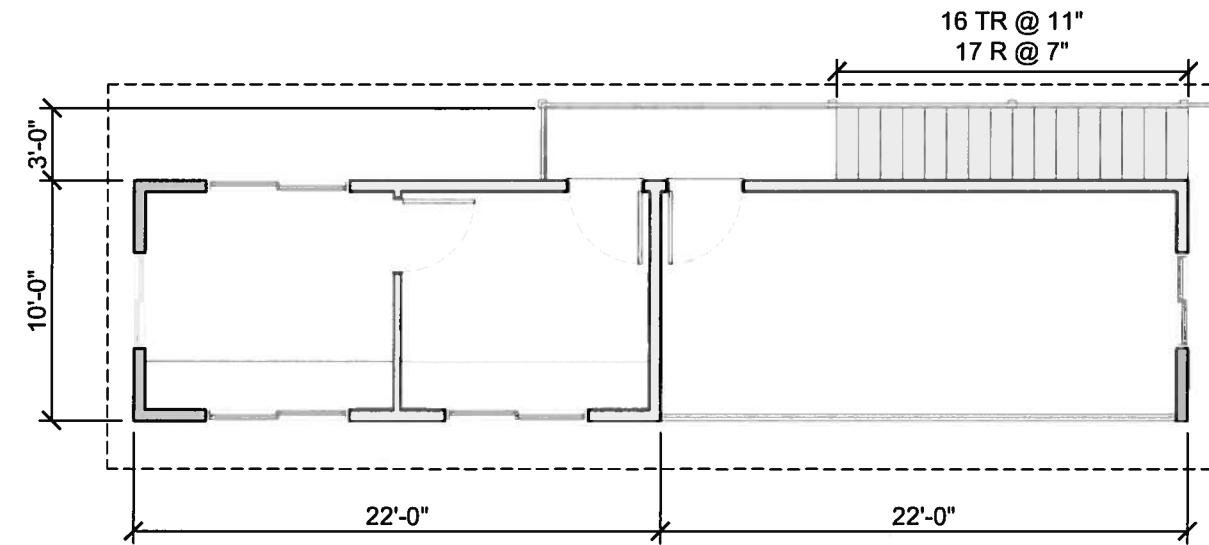

1
SD2

**Crows Nest
Upper Floor Plan**

1/8"=1'-0"

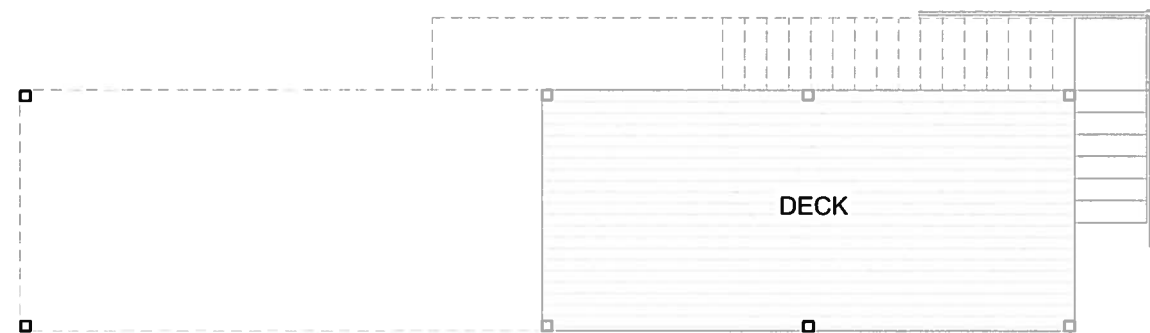

2
SD2

**Crows Nest
Lower Floor Plan**

1/8"=1'-0"

NOT FOR CONSTRUCTION - PRELIMINARY DESIGN

TETON COUNTY FAIR GROUNDS
CROWS NEST
JACKSON WY

TAG #	REVISION	DATE
1	SD1	6/30/14

DRAWN BY	AJ	REF SHEET #
CHECKED BY	BH	SHEET #
CTA #	JACFAIR2	2